



NORDdamper Dampers

 **ETS NORD**

All about air



Contents

KROS

Regulating damper

3



KRTS-4

Shut-off and regulating damper

6



KRI

Damper with flow meter

9



KR

Regulating and shut-off damper

13



KRU

Regulating and shut-off damper

15



KROS Regulating damper

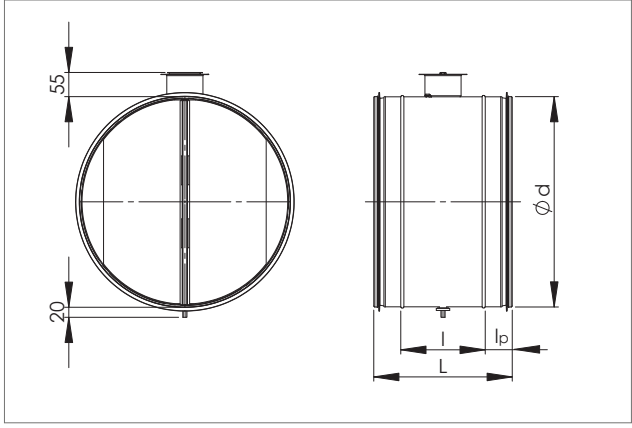
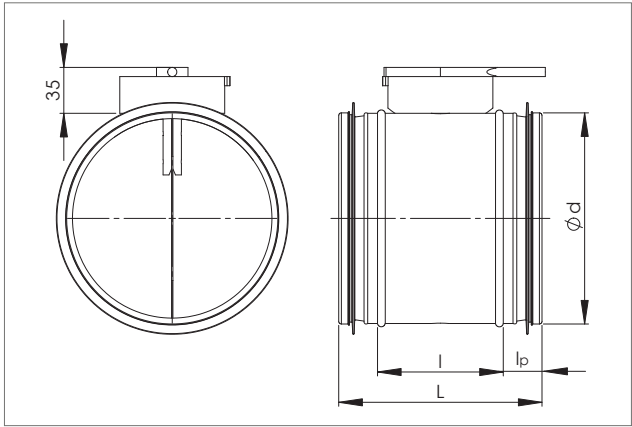

4

NORDdamper | KROS

Damper for regulating air flow in round duct systems.

- Steplessly adjustable
- Short structure
- Easy to install
- Equipped with rubber gaskets
- Tightness class EN 1751, class C

Structure and dimensions

Manufactured of galvanized steel. Equipped with rubber gaskets. Polyamide bushings (max +150°C). Manually adjustable.

Nominal size, d mm	l, mm	lp, mm	L, mm	Weight, kg
80	95	29	155	0,29
100	95	29	155	0,35
125	95	29	155	0,45
160	95	29	155	0,6
200	95	29	155	0,75
250	95	50	215	1,4
315	95	50	215	1,9
400	95	50	215	3,1
500	125	65	255	4,4
630	125	65	255	6,0



Technical data

4

NORDdamper | KROS

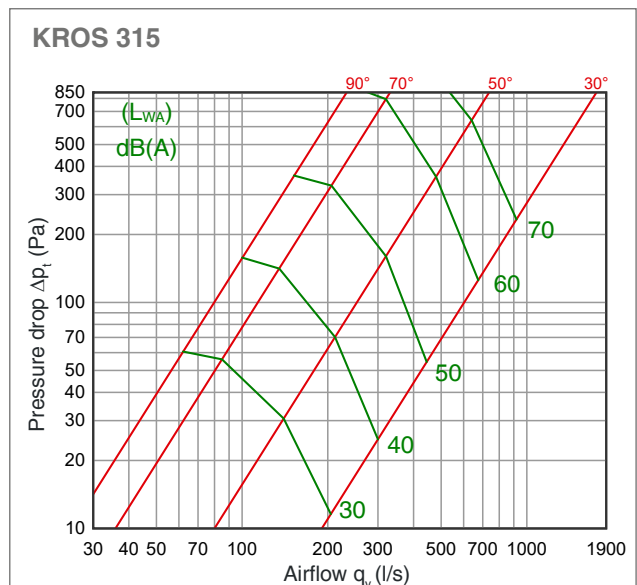
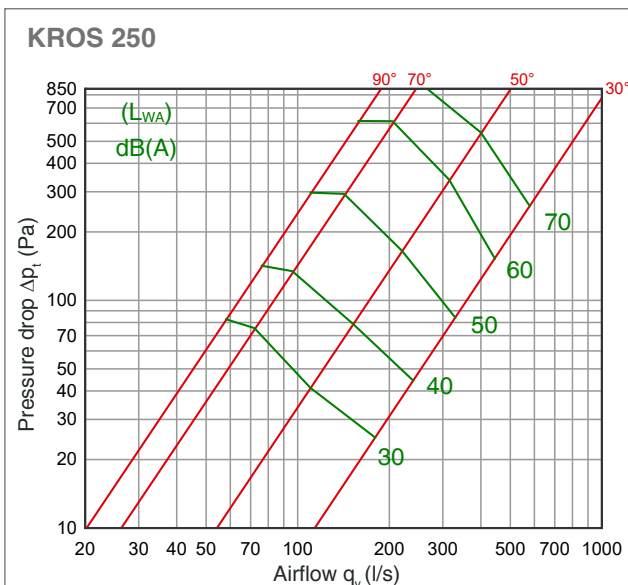
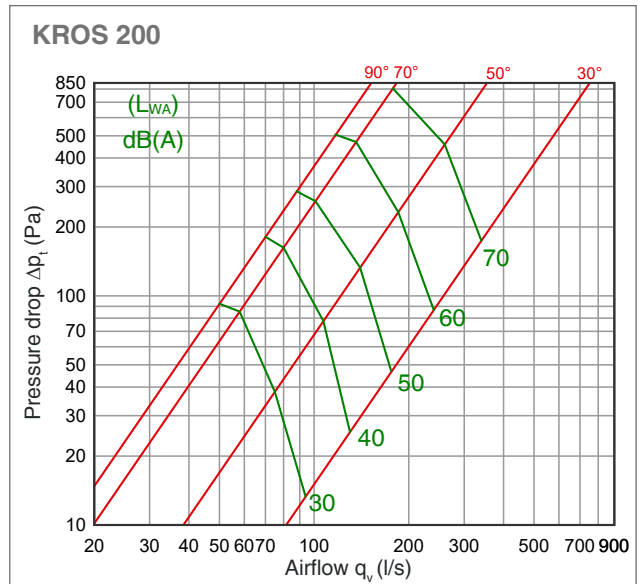
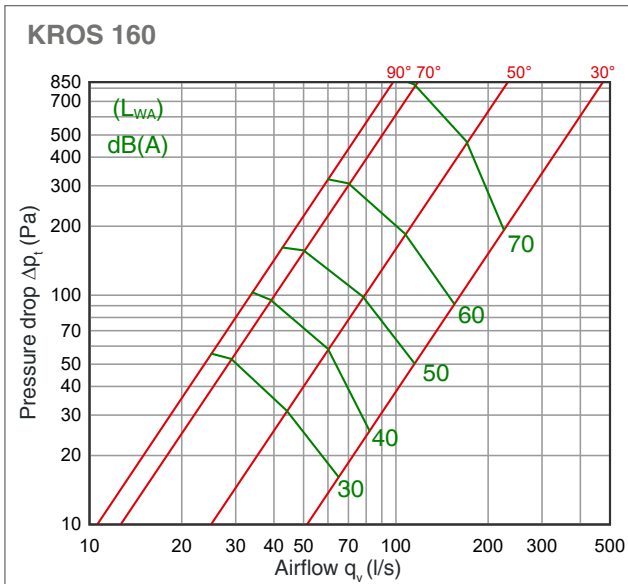
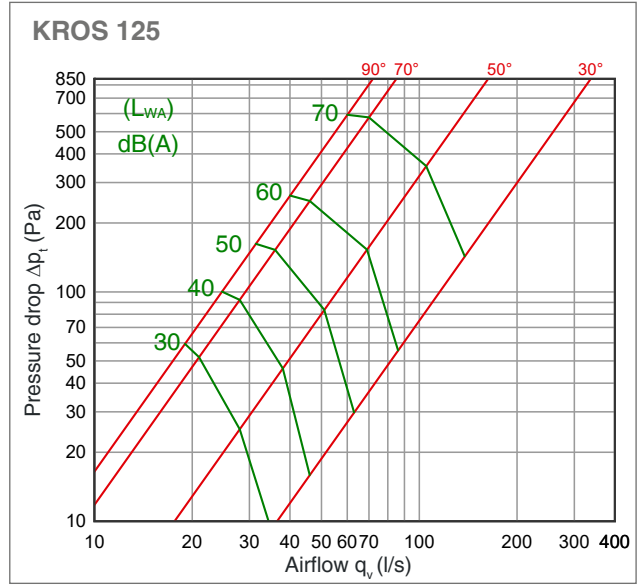
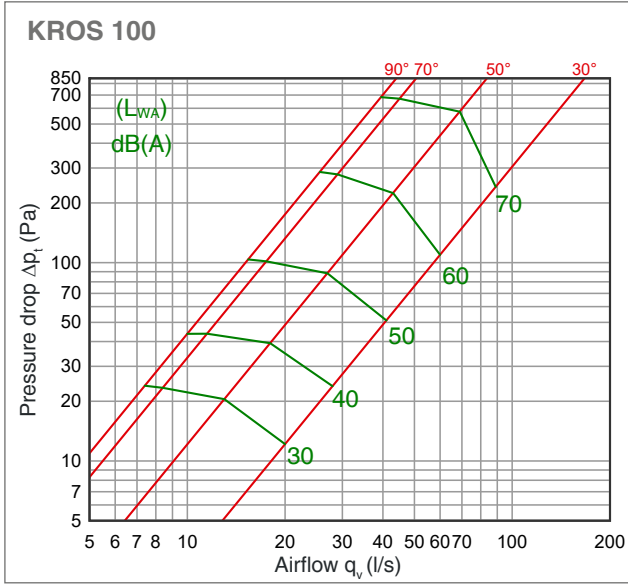

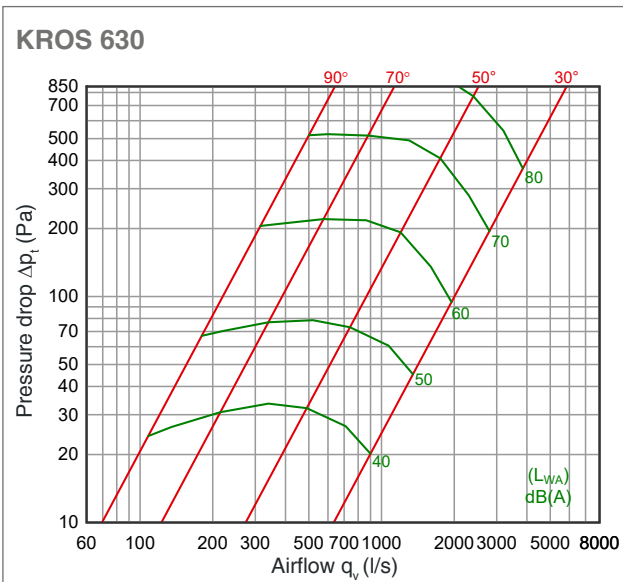
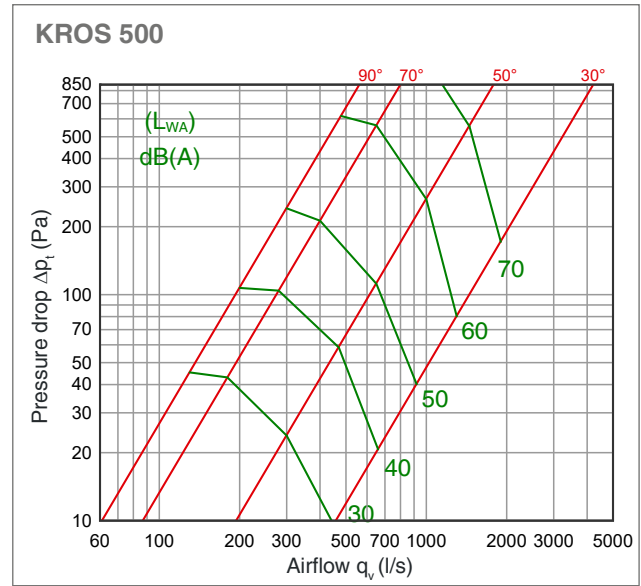
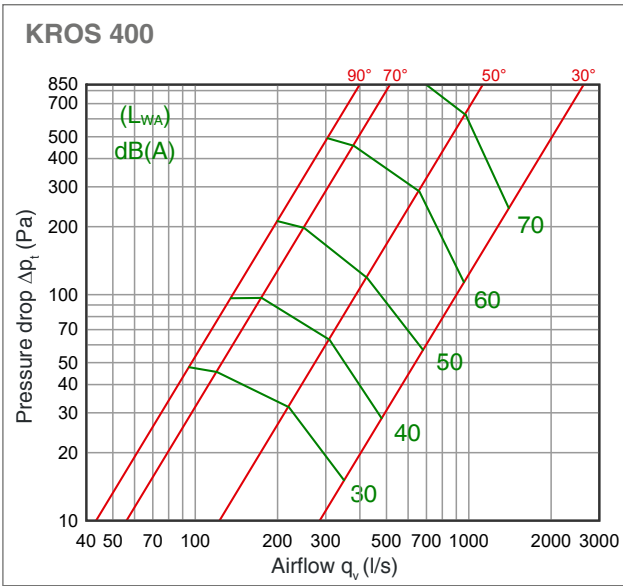

4

NORDdamper | KROS

Marking

KROS	Ød
Symbol	Diameter

Example: KROS 315

Installation

Installation according to NORDduct installation instructions.

KRTS-4 Shut-off and regulating damper

Dampers for shut-off and regulating of air flow in round duct systems.

KRTS-4 sealed version. Casing tightness class C and shut-off tightness class 4 (standard EVS-EN 1751:2014).

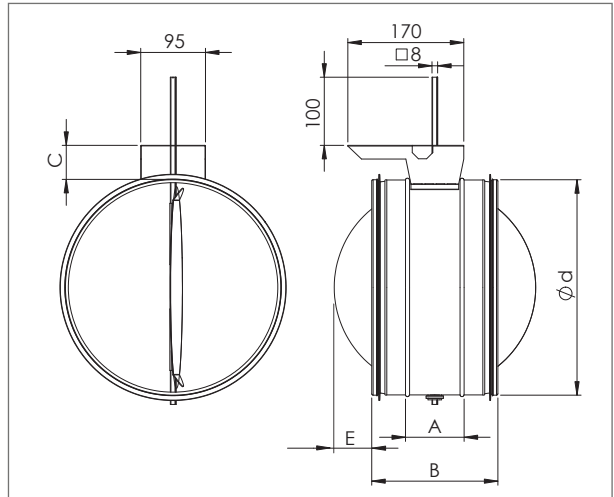

Structure and dimensions

Manufactured of galvanized steel. Equipped with rubber gaskets. Can also be manufactured of other materials. For automatic regulation of air flow, various motors can be used. For manual regulation, a handle can be installed. See: Accessories.

4

NORDdamper | KRTS-4

Nominal size, mm	A	B	C	Weight, kg	Recommended actuator	
					Without spring	Spring return
100	95	155	30	0,6	CM24-R/CM230-R	TF24/TF230
125	95	155	38	0,7	CM24-R/CM230-R	TF24/TF230
160	95	155	45	0,9	CM24-R/CM230-R	TF24/TF230
200	95	155	46	1,1	CM24-R/CM230-R	TF24/TF230
250	117	215	50	1,6	LM24A/LM230A	LF24/LF230
315	117	215	50	2,1	LM24A/LM230A	LF24/LF230
400	117	215	52	3,2	LM24A/LM230A	LF24/LF230
500	125	255	55	4,7	LM24A/LM230A	NF24A/NF230A/NFA
630	125	255	55	6,3	LM24A/LM230A	NF24A/NF230A/NFA

NB! Damper weights do not include the weight of actuators

Belimo actuators: consider surface area of the blade, structure, installation and air flow. N.B. Belimo actuators manuals: www.belimo.com.

	Without spring			Spring return	
	CM	LM...A	TF	LF	NF
Torque	2 Nm	5 Nm	2,5 Nm	4 Nm	10 Nm
Weight	0,22 kg	0,65 kg	0,69 kg	1,5 kg	3,0 kg

Technical data

KRTS-4, shut-off tightness class 4

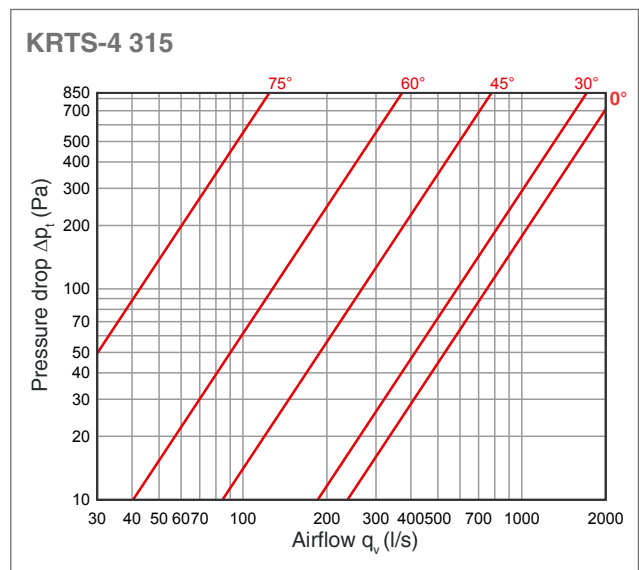
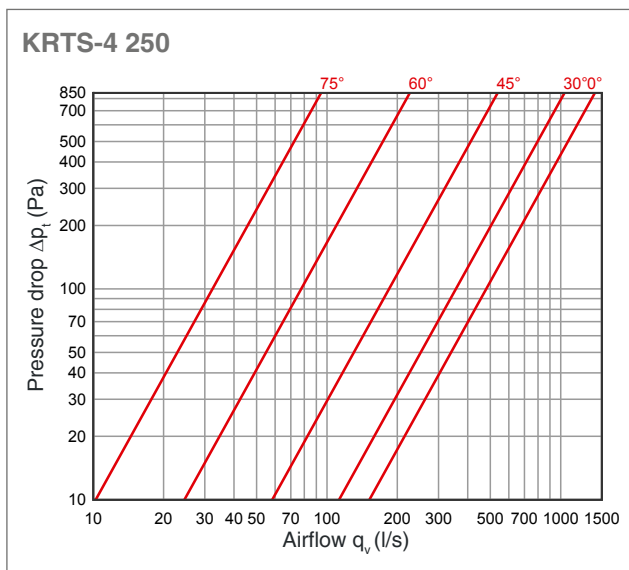
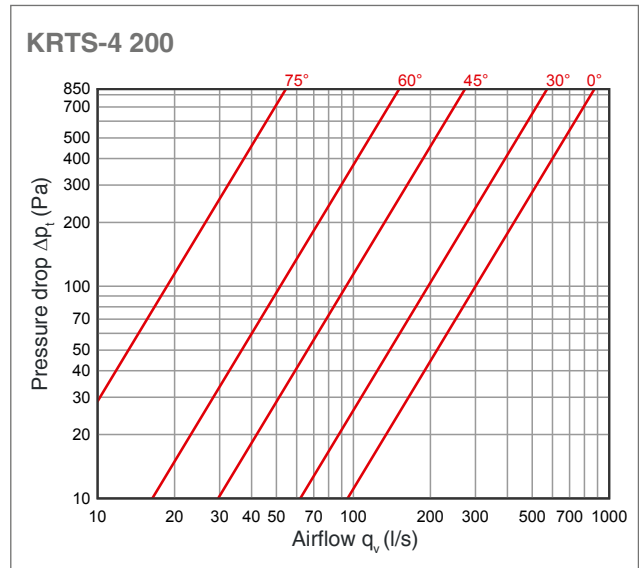
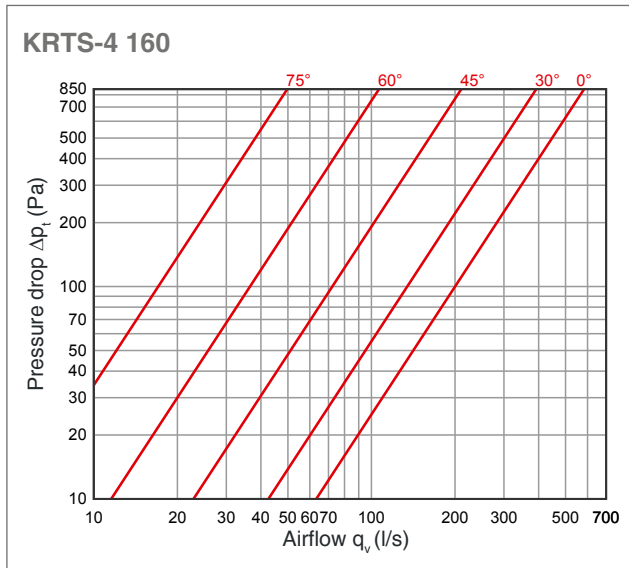
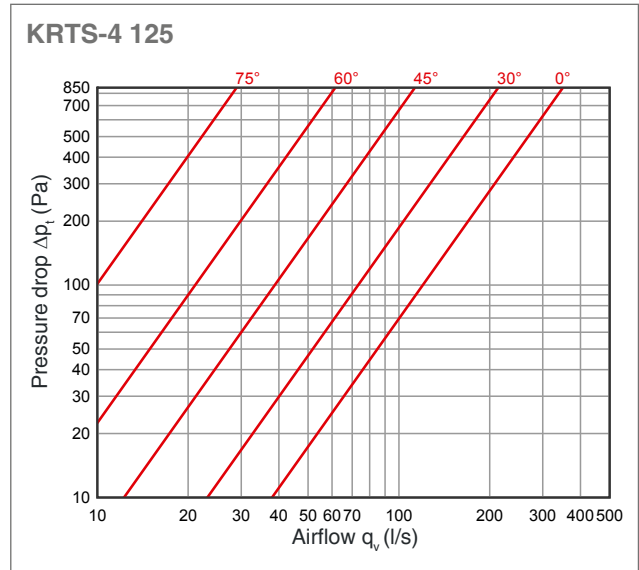
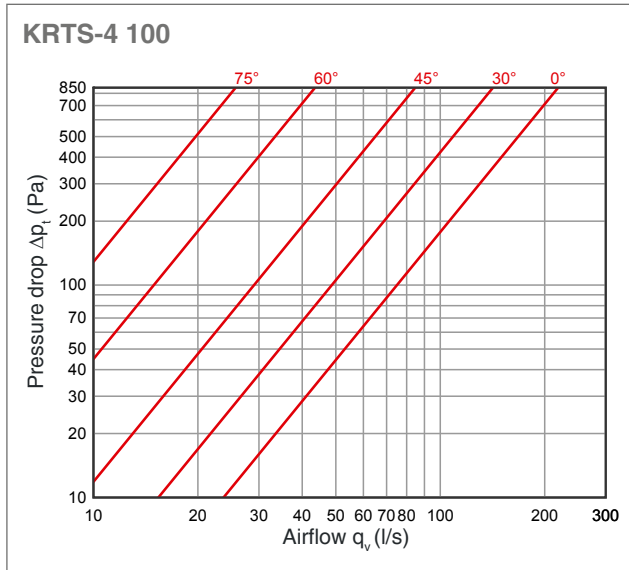

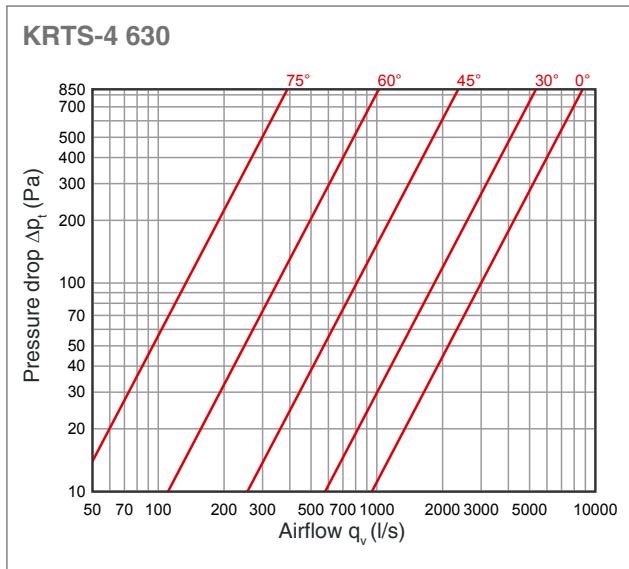
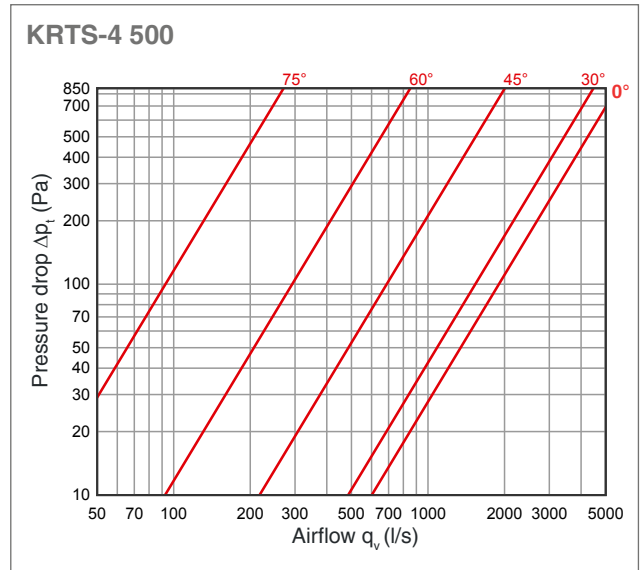
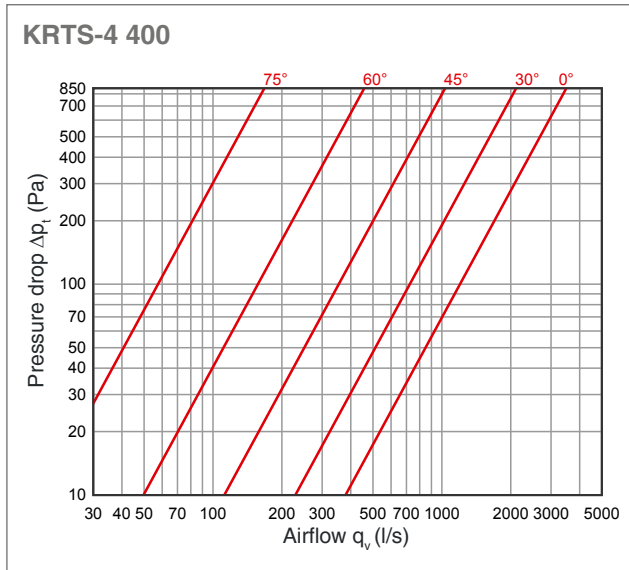

Marking

KRTS-4	Ød
Symbol	Diameter

Example: KRTS-4 315

Material codes

- H – acid-proof steel (standards EVS-EN 10088-2:2014, EN 1.4436 or AISI 316)
- ZM – Zinc-magnesium coated steel (standard EVS-EN 10346:2015, DX51D+ZM310)

Accessories

Handle: for models KRTS-4.

Installation

Installation according to NORDduct installation instructions. For electric installations, see: www.belimo.com.

KRI Damper with flow meter

KRI is an iris-type damper for measuring and regulating air flow.

Air flow measuring and regulating is done easily by using measuring nozzles and turning the regulating bolt, which turns the blades. See: Measuring and regulating air flows.

By opening the blades a full access to the system is provided for cleaning.

Tightness class EN 1751, class C.

Structure and dimensions

The damper and blades are manufactured of galvanized steel. Regulating bolt, regulating graph and measuring nozzles are made of plastic.

Duct connections with rubber gaskets. Measuring nozzles on both sides of the blades.

Can be operated in 80°C and momentarily in 120°C.



Nominal size, Ød mm	ØD mm	l mm	L mm	Weight, kg
KRI 100	160	60	115	0,6
KRI 125	185	60	110	0,7
KRI 160	225	60	115	1,0
KRI 200	280	65	120	1,4
KRI 250	330	75	135	1,9
KRI 315	405	75	135	2,5
KRI 400	525	55	190	6,4
KRI 500	655	70	170	9,6
KRI 630	815	70	170	15,6
KRI 800	1015	70	270	25,0

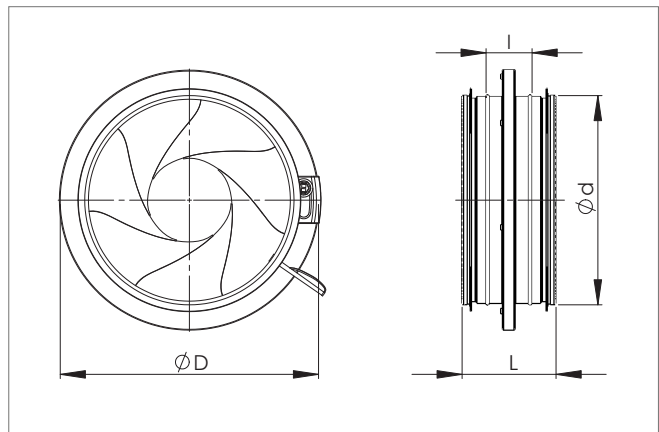

Technical data

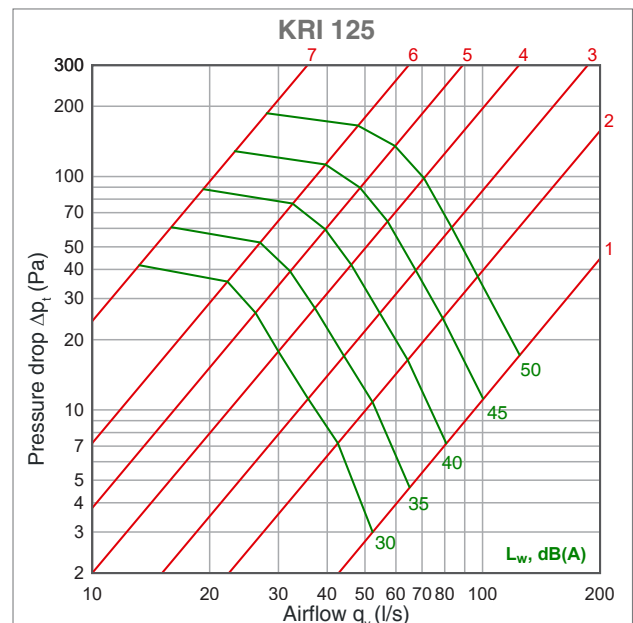
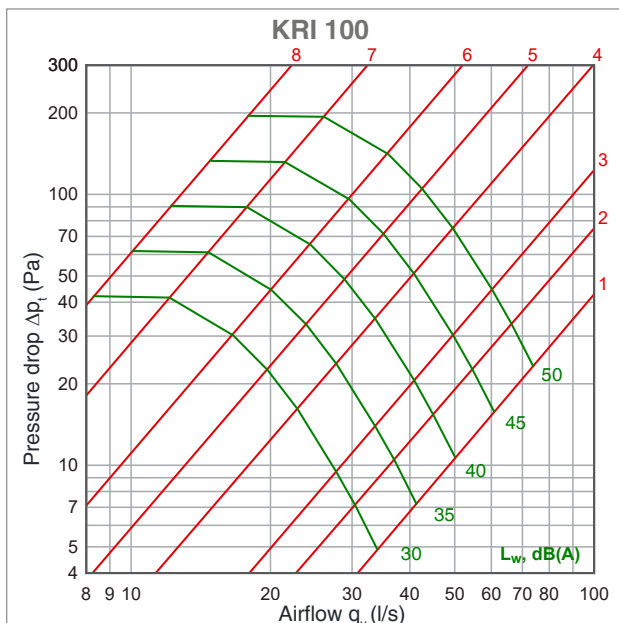

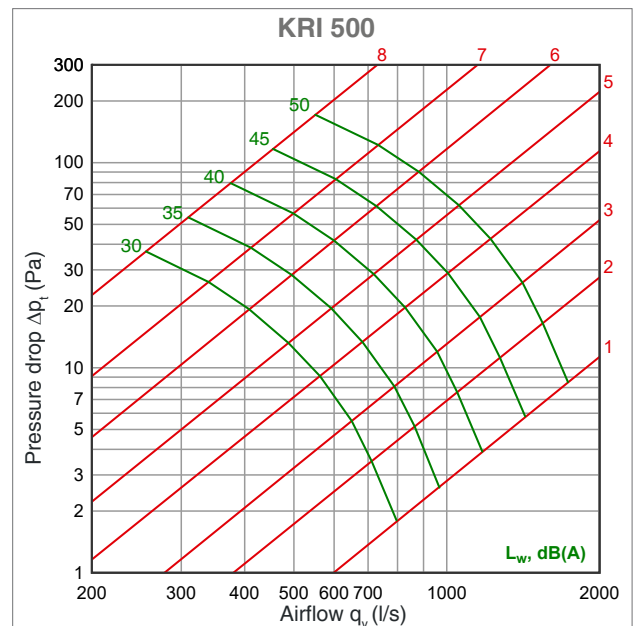
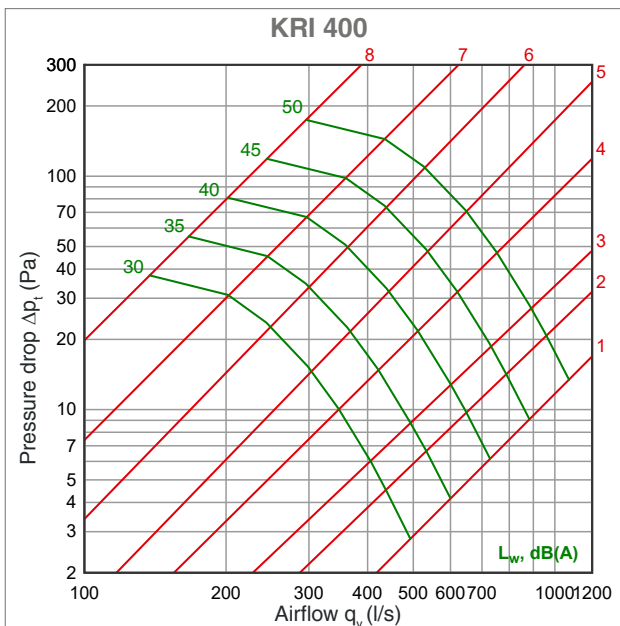
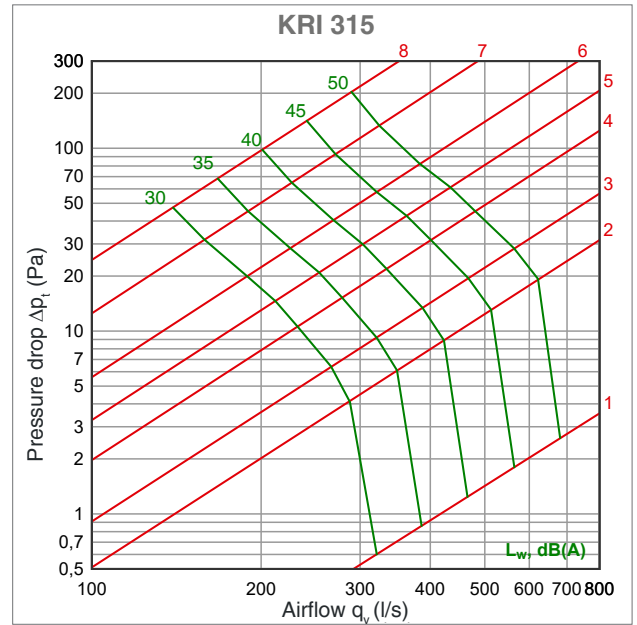
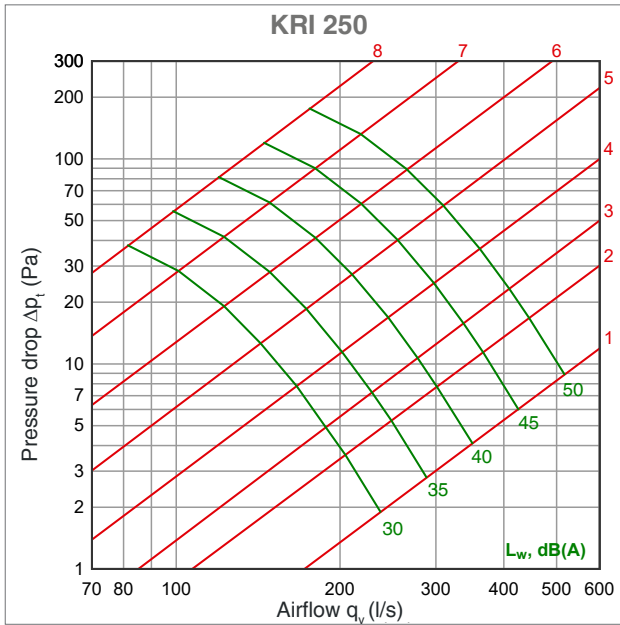
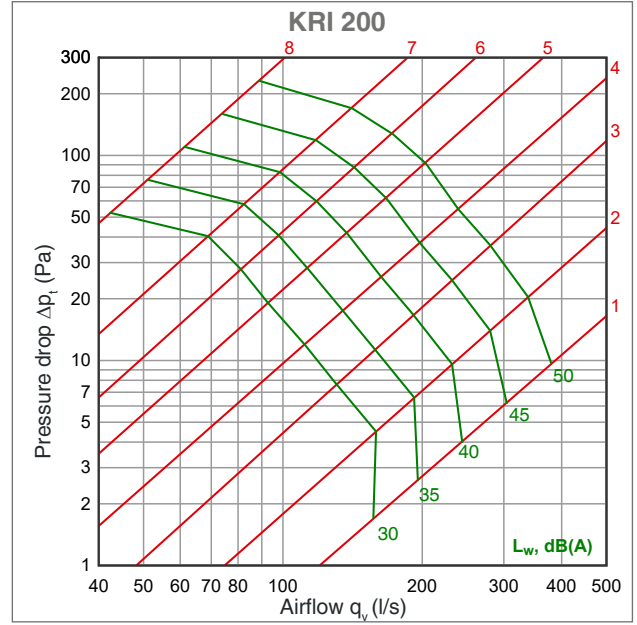
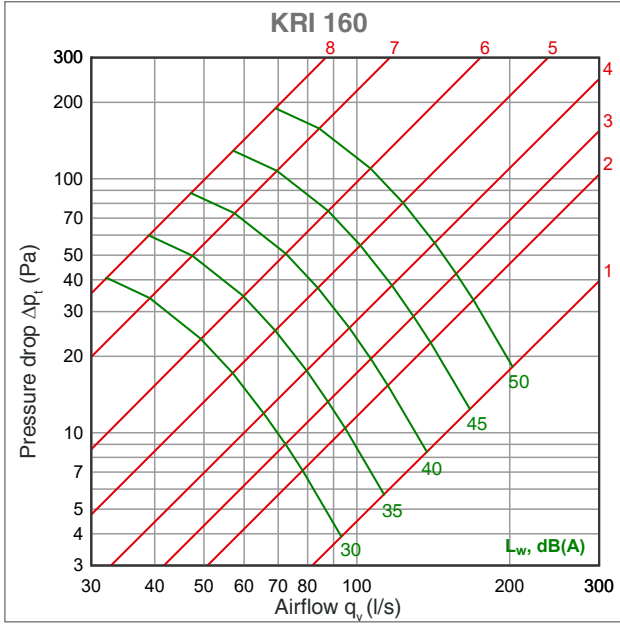

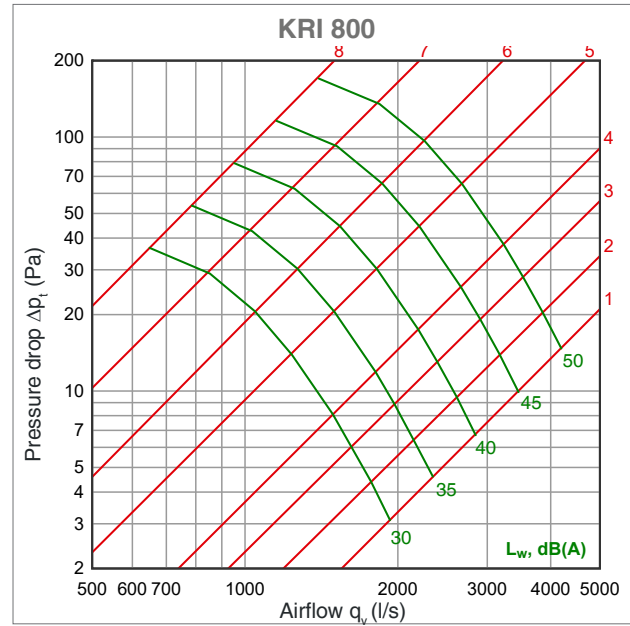
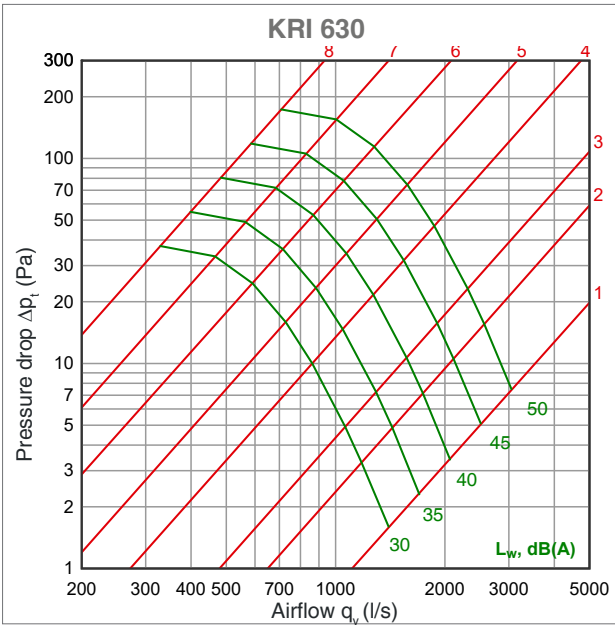

Sound power level L_w

	Correction of sound level K_{okt} [dB]							
	63	125	250	500	1000	2000	4000	8000
KRI 100	8	7	4	-3	-8	-15	-18	-25
KRI 125	9	7	3	-3	-8	-13	-18	-24
KRI 160	11	9	4	-3	-9	-12	-18	-25
KRI 200	14	9	3	-3	-9	-11	-18	-25
KRI 250	16	10	2	-4	-8	-12	-21	-26
KRI 315	19	10	2	-5	-7	-14	-23	-26
KRI 400	19	8	2	-3	-8	-15	-22	-26
KRI 500	19	6	3	-2	-9	-15	-20	-25
KRI 630	20	8	2	-3	-9	-15	-20	-26
KRI 800	21	9	2	-4	-10	-15	-20	-27
Tolerance ±	4	4	4	4	4	4	4	4

The sound power levels of the duct for every octave band are obtained by adding the corrections K_{okt} of octave bands (see table above) to the total sound pressure level L_{p10A} , dB(A), according to the following formula:

$$L_{W_{okt}} = L_{p10A} + K_{okt}$$

Correction K_{okt} is the average in the range of use of the regulation and measuring device.

Data for smoke restriction

KRI-100 and KRI-125 meet the requirements of RakMK E7:2004 for dampers (42 dm³/s, 100 Pa), when KRI-100 regulation value ≥ 6,0 and KRI-125 regulation value ≥ 5,5.

Marking

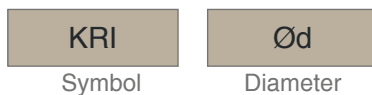

Example: KRI 100

Installation

KRI damper is installed as other parts and secured with rivets. See NORDDuct installation instructions. When installing you should be followed the required safety distance and right mounting distance. In the vertical duct system duct must be supported in order to avoid compression of the damper..

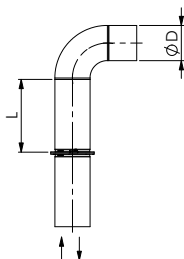
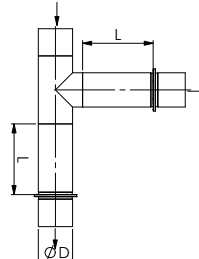
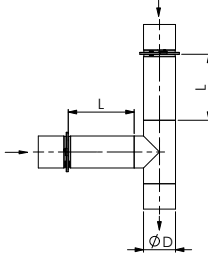
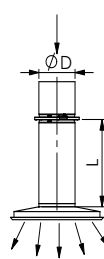
The specific situation				
The required safety distance L Method error ±7%	$L \geq 1D$	$L \geq 4D$	$L \geq 2D$	$L \geq 2D$

4

NORDDamper | KRI

Measuring and regulation

Air flow is calculated using the measuring diagram. By measuring the pressure difference between the measure nozzles, you can read the air flow from the diagram. Air flow is regulated by turning the regulat-ing bolt. The measuring diagram follows the product. N.B. The diagrams in this manual consider the technical data of the damper itself, and cannot be used for measuring air flows.

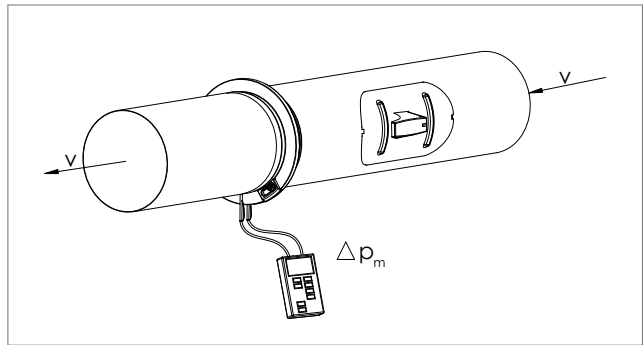

Cleaning

Note the regulation data. By fully opening the damper, one gets access to the duct. Do not forget to readjust the damper after cleaning.

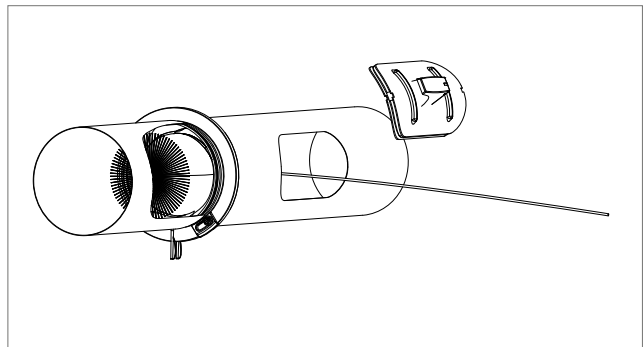

KR Regulating and shut-off damper

Damper for shut-off and regulation of air flow in rectangular duct systems.

Versions

KR dampers are manufactured in 4 versions:

KR2 – Damper, tightness class 1 (EVS-EN 1751:2014). For regulating air flow in duct systems.

KR4 – Edge-sealed damper for shut-off and regulation, tightness class 3 (EVS-EN 1751:2014). For systems with high requirements for tightness.

KR4-S – Edge-sealed damper for shut-off and regulation with thermal insulation, tightness class 3 (EVS-EN 1751:2014). For systems with high temperature variations and high requirements for tightness.

KR4-S soojapidavuse kordaja $U_m=4$ W/m²K.

KR4-S LE - Edge-sealed damper for shut-off and regulation with thermal insulation, tightness class 3 (EN 1751:2014).

KR type of damper external casing leakage class is C according to EVS-EN 1751:2014.

Structure and dimensions

KR dampers are manufactured of galvanized steel. Blade bearings polyamide.

KR2 - blades made of galvanized steel sheet, no extra gaskets.

KR4 - profiled blades with polyamide edges and silicone gaskets.

KR4-S - blades filled with mineral wool.

All blades with profiled sandwich structure and smooth surface to prevent thermal bridges and dirt accumulation.

Measurements

Width B 200 mm,, 3000 mm

Height H 200 mm,, 3000 mm, when H>2000 mm 2 motor shelves needed.

B x H Max 5 m², if surface area >5 m², 2 or more dampers are needed.

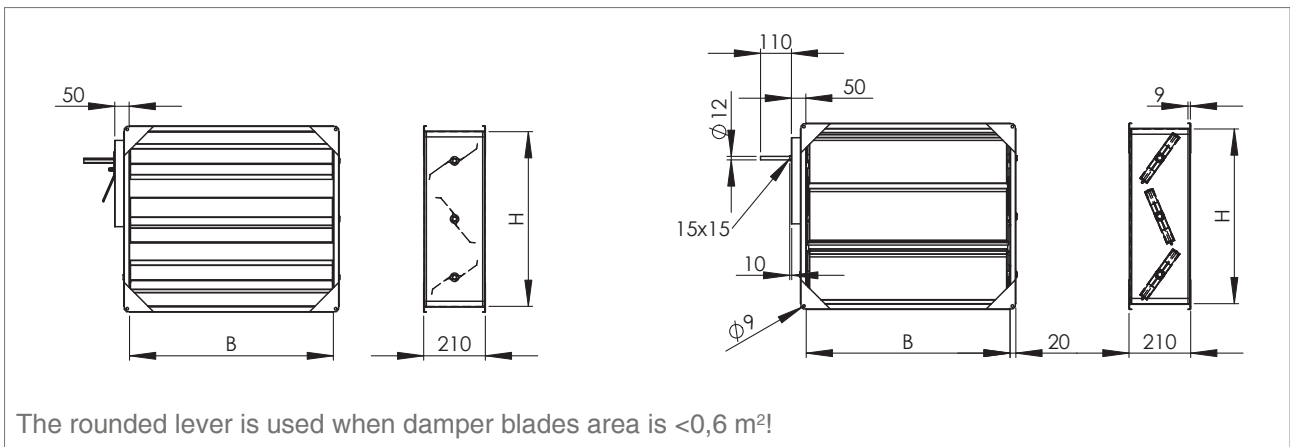

Technical parameters

KR-type regulating damper blades density class has been tested according to standard EN 1751: 2014.

4

NORDDamper | KR

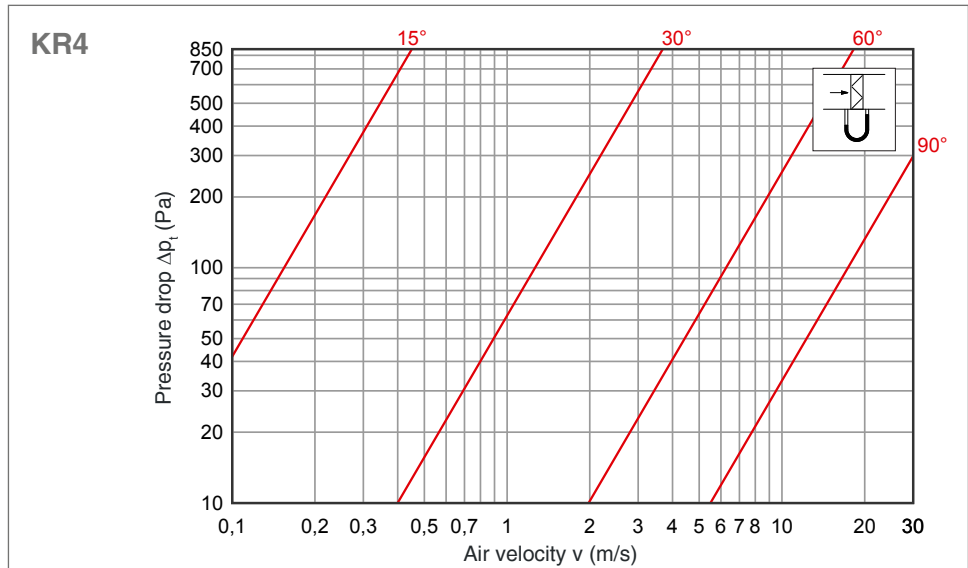
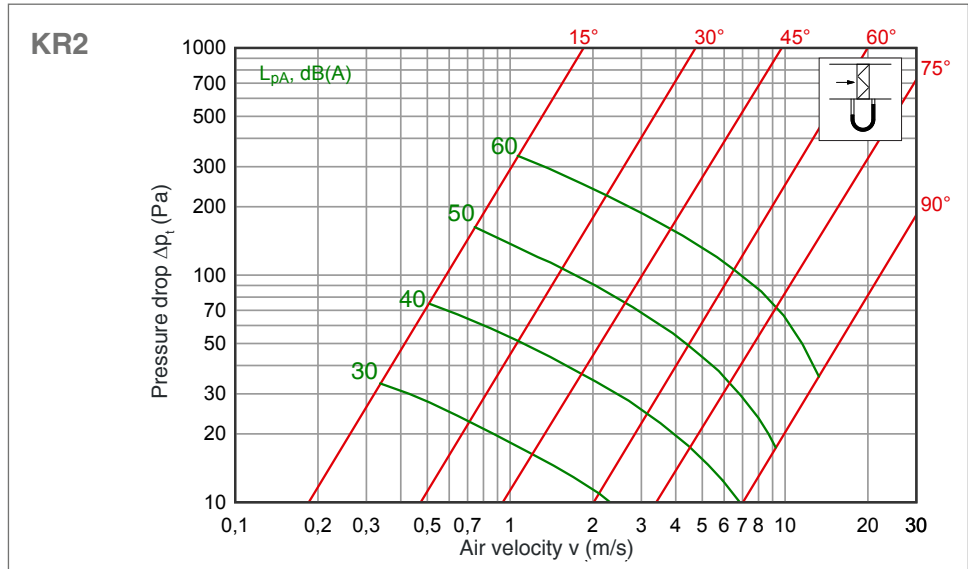

Marking

KR2	B x H	K	D1=400
Type KR2 tightness 1 KR4 tightness 3 KR4-S tightness 3, with insulated blades	Width x Height	K - manual adjustment M - motor base	D1- round connection D2 – round connection both ends

Example: KR4- 400x400- K

Material codes:

H - acid-proof steel (standards EVS-EN 10088-2:2014, EN 1.4436 or AISI 316)
 ZM -zinc-magnesium coated steel (standard EVS-EN 10346:2015, DX51D+ZM310)

KRU Regulating and shut-off damper

KRU - rectangular regulating and shut-off damper is designed for closing air ducts and adjusting the air flow in ventilation systems.

KRU - sealed regulating and shut-off damper with thermally insulated blades, air tightness class 4 (EN 1751).

Damper versions:

KRU - sealed regulating and shut-off damper.

KRU-25 - sealed regulating and shut-off damper with thermally insulated blades, the measured thermal transmittance

$$U_d = 2,5 \text{ W/(m}^2\text{K)}.$$

KRU-23 - sealed regulating and shut-off damper with thermally insulated blades and an thermally insulated external casing, the measured thermal transmittance

$$U_d = 2,3 \text{ W/(m}^2\text{K)}.$$

Areas of use

Used in air duct systems, in which significant temperature differences and good tightness and thermal insulation are required.

The normal operation temperature area is $-40^{\circ}\text{C} \dots +80^{\circ}\text{C}$.

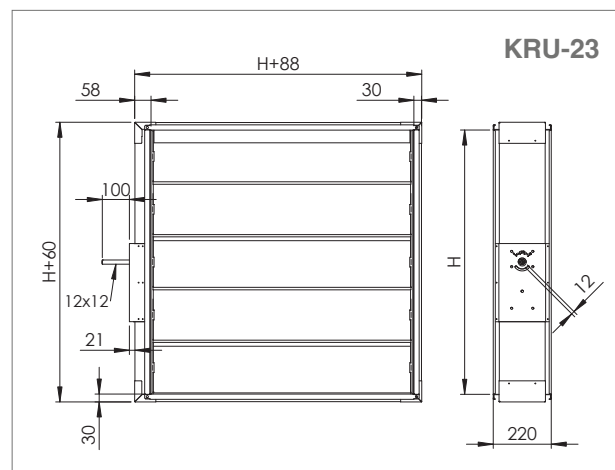
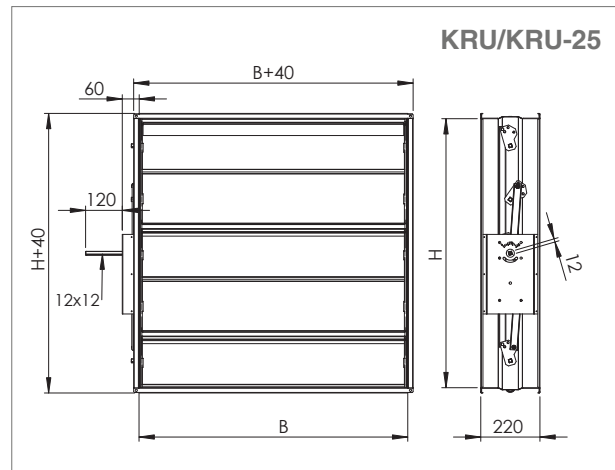

Structure and dimensions

KRU dampers are manufactured of galvanized steel. The blades rotate in the case on polyamide bearings. The damper has profiled blades with polyamide covers at the ends and silicone-sealed edges. The blades are filled with mineral wool.

All blades have a profiled sandwich structure and smooth surface to prevent thermal bridges and dirt accumulation. The dampers are equipped with a motor base. When the surface area is bigger than $5,2 \text{ m}^2$, the damper is compiled of two or more units, of which each is equipped with their own actuator.

Measurements

Width B	200, +1,, 2600 mm
Height H	200, +50,, 2950 mm (the blade width is 200 mm)
B x H	If the surface area is $>5,2 \text{ m}^2$, use two or more dampers

Technical data

KRU type of damper external casing leakage class is C and the air tightness class of the damper is 4 (according to EN 1751:2014).

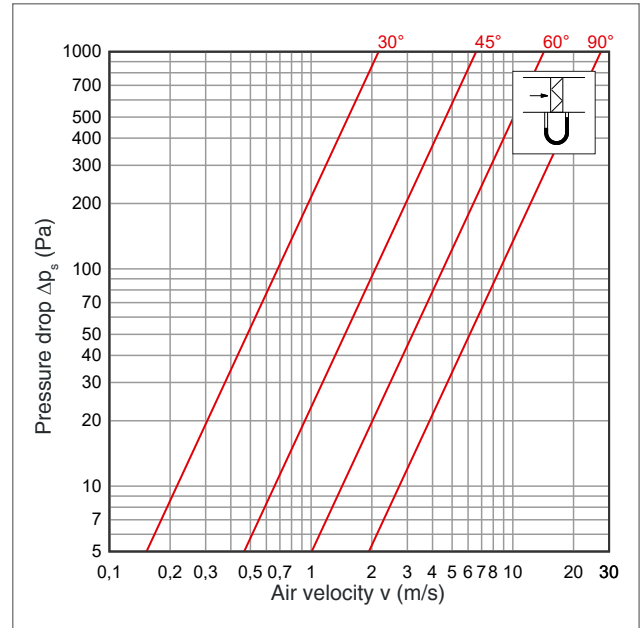
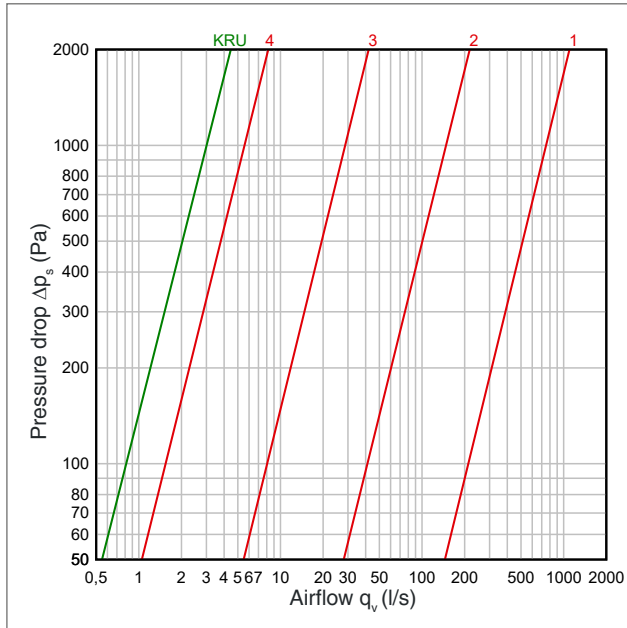

Damper weight

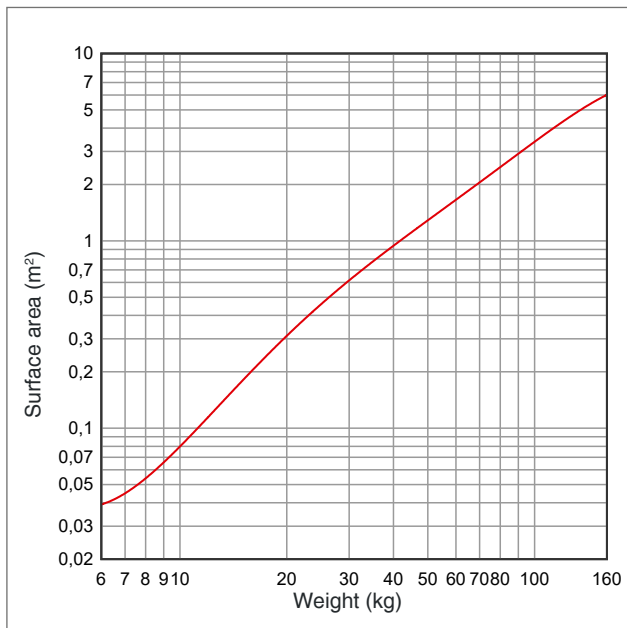

Torque

The torque needed for closing the damper.

Damper height, H	Width B				
	500	1000	1500	2000	2600
2000	20	30	30	30	30
1500	20	20	30	30	30
1000	15	20	20	30	30
500	15	15	20	20	20

Actuator capacity 15 Nm 20 Nm 30 Nm

Marking

KRU	25	B x H	D1=400	L-50
Symbol	Thermal conductivity 23 25	Width x height	Round connection	Wall mount

Product:

- KRU = Edge-sealed damper for shut-off and regulation, air tightness class 4
- KRU 25 = Edge-sealed damper for shut-off and regulation with thermally insulated blades, $U_d=2,5 \text{ W}/(\text{m}^2\text{K})$
- KRU 23 = Edge-sealed damper for shut-off and regulation with thermally insulated blades and casing, thermal conductivity $U_d=2,3 \text{ W}/(\text{m}^2\text{K})$

Dimensions: = Duct dimensions A x B (mm)

Accessories:

Round connection

D1 = Round connection on one side (add the location of the actuator viewed from room)

D2 = Round connections on sides

Wall mount

R = Wall profile, actuator on the right

L = Wall profile, actuator on the left

Example: KRU 25 400x400 D1=400 L

Installation

KRU-type dampers are installed to ventilation units or ducts using euro(E20) or z-joining profiles. Blades can be installed horizontally or vertically.

When installing damper the cross-sectional requirement must be monitored. The deviance of the dampers body is $\pm 1^\circ$. Bigger angel deviation can cause stuck of the blades.

For round connection suitable joint must be ordered and used. The connection is mounted to the duct with rivets. If the round connection is only on one side, add the location of the actuator to the product marking seen from the room side. When using a damper with an actuator, note that there is sufficient space between the damper and any other parts, for example duct or wall, for replacing the actuator.

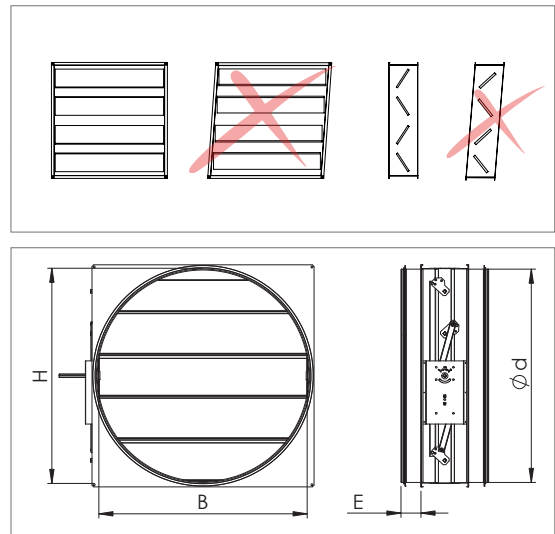

Wall mounting

The damper is installed to the wall with the factory-installed L profiles (L profile width 50 mm, a different profile width to cover the hole is marked after the wall mount marking). For wall mounting select the fixing accessories according to the wall material and damper weight.

Note! The location of the actuator must always shown from the room side!

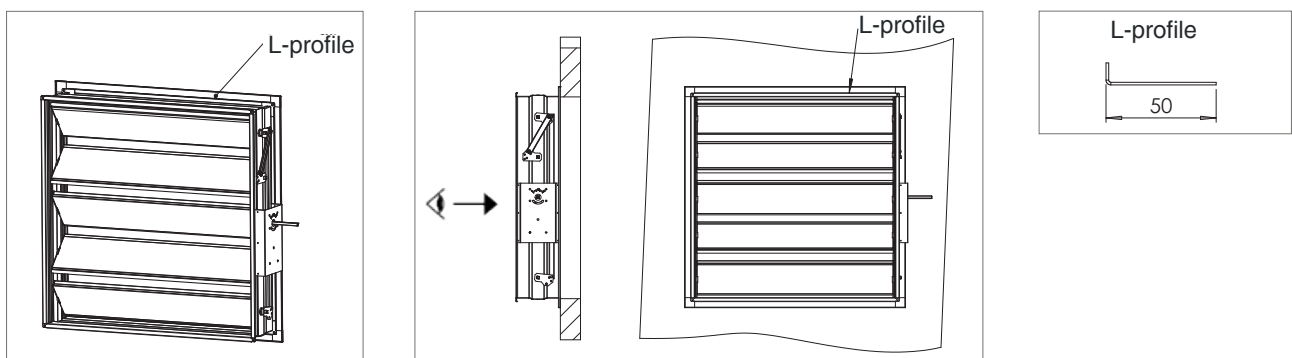



ETS NORD AS

Address: Peterburi tee 53
11415 Tallinn
Estonia

Phone: +372 680 7360
info@etsnord.ee
www.etsnord.ee

ETS NORD Finland

Address: Pakkasraitti 4
04360 Tuusula
Finland

Phone: +358 0401 842 842
info@etsnord.fi
www.etsnord.fi

ETS NORD Sweden

Address: Järsjögatan 7
69235 Kumla
Sweden

Phone: +46 707 80 50 16
info@etsnord.se
www.etsnord.se

ETS NORD Denmark

Address: Nordholmen 6
2650 Hvidovre
Denmark

Phone: +45 6010 1750

Address: Nygade 109 B
7430 Ikast
Denmark

Phone: +45 9712 1314
info@etsnord.dk
www.etsnord.dk

